

It is recommended that only persons who have sufficient knowledge and experience such as system designers and responsible persons deal with this product after carefully reading the product manual.

**1 The matters of safety**

**WARNING**

- \* If the equipment is used in a manner not specified by the manufacturer, the protection provided by the equipment may be impaired.
- \* Do not let the water touch the product. It may cause electric shock or fire due to malfunction.
- \* When you check or maintain the product, make it sure you turn off the power. It may cause electric shock or fire due to malfunction.
- \* Secure the product firmly when you want to secure it. There is a possibility of accident due to fall-over or malfunction, etc.
- \* Secure working space when you install the product. If working space is not secured, the checking or maintenance of the product is made impossible leading to failure of the product.
- \* Always use either one of the following materials for air supply: CDA(Celan Dry Air) or N2. If there are any water or oil contamination in the air supply, it will cause malfunction or cause of accident.
- \* Do not use the product at the place where dangerous material such as inflammable or ignitable material exists. This product is not the product of anti-explosive type.
- \* This device is made only for industrial uses. You need to ground the device beforehand. Otherwise, there are in case of malfunction, electric shock, or fire damage.

**CAUTION**

- \* Do not contact the discharge needle or terminal with power applied. There is a possibility of electric shock or malfunction.
- \* Handle the discharge needle with care as its tip is very sharp.
- \* Connect wires referring to the product manual. Wrong connection can cause failures.
- \* Take precautions as cables of the adaptor, the power line and communication line of each product may disconnect. If the cable is damaged, replace it immediately.
- \* Do not use the product for the purpose outside of the range of the product use. If the product is used for the purpose outside of the range of the use, it can result in the trouble or the shortened service life. Or an unexpected problem may occur.
- \* The ionizer generates ozone(below 0.05ppm) if you sense the smell of ozone when you use more than two units, ventilate the air.
- \* When installing or transporting the ion bar, be prepare not to bend the item during the process.

**2 Check the package contents**

**Product compositions**

The package includes the following products composition.

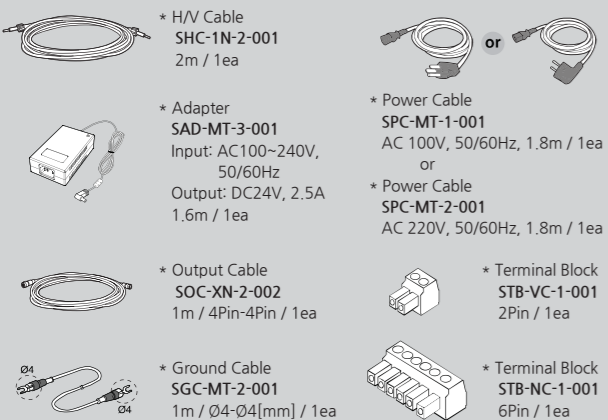
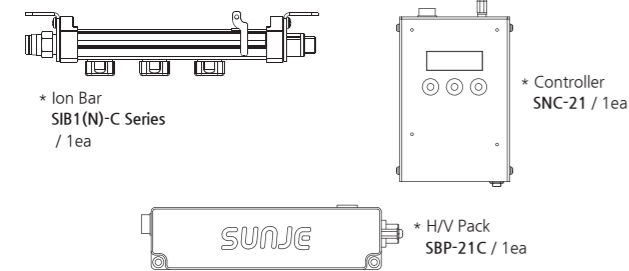

**Option**

If you require extra functions with the basic accessories we provided, you need to purchase optional items in below for further assistant.

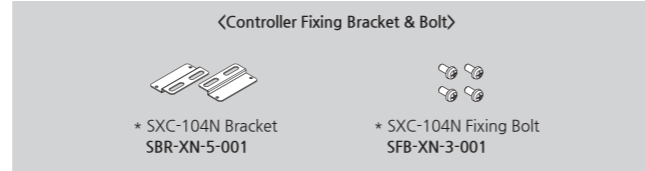

**3 Nomenclatures of parts**

**SIB1(N)-C (Ionizer)**

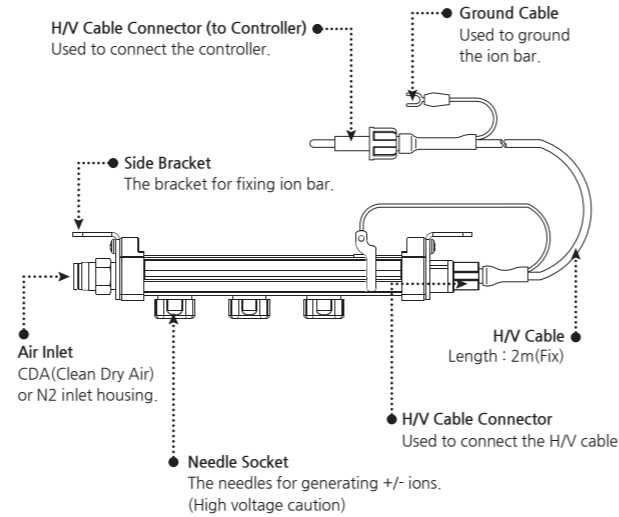

**SNC-21 (Controller)**

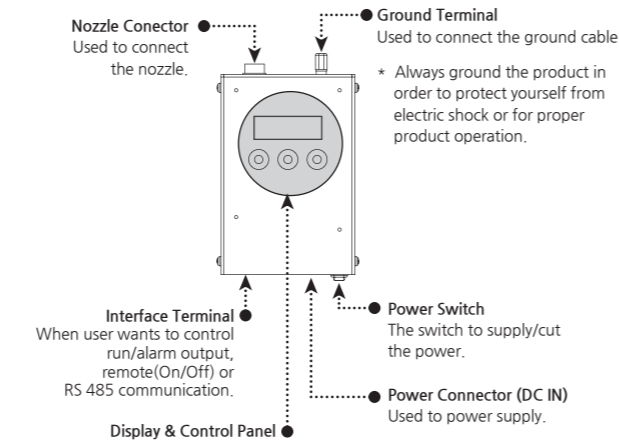

No	Name	function
1	RX / TX (LED)	Light on when using RS-485.
2	Alarm (LED)	Light on when Alarm occurs.
3	FND Display	<A-01 ~ 16> : Address <AL-1> : When high voltage error, display and operation stop. <AL-2> : When over-discharge of electrode or leakage occurs, display and operation stop. <AL-3> : When tip cleaning setting time is over.
4	Tip Cleaning (LED)	Light on when tip cleaning setting time is over.
5	RUN (LED)	Ion Bar Lights up during normal operation.
6	SET Button	It is for changing the address, frequency Setting.
7	Up / Down Button	

\* If operation stops when AL-1 or AL-2 or AL-3 occurs, turn the product off and then on again.

**4 Installation and connection**

**Ion bar installation**

When you install the ion bar, please check the distance between ion bar and object.  
\* Please, handle with care when you carry or install not to break or bend an ion bar.

**CAUTION** \* The radius of curvature of the air hose is Install with R10mm or more for operation. (Due to excessive bending of the air hose the product may be damaged.)

**Interference by Grounding Matters**

If there is any conductive object close to ion bar, it may not operate properly. Please install it with reference to figure below.

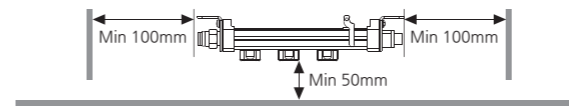

**Side to Side Installation**

When the more than two ion bars are installed, to avoid interference, the range between two ion bars should be more than 400mm.

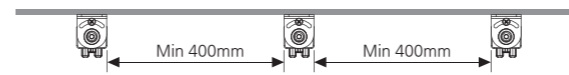

**Face to Face Installation**

When two ion bars are installed face to face, to avoid interference, the range between two ion bars should be more than 100mm.

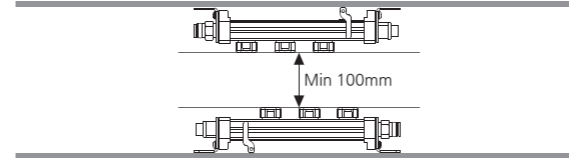

**Air supply method**

**CAUTION**

- \* Air supply is one of the key factors. Please read the followings carefully in advance.
- \* If many ion bars are connected to one air line, with air lack of pressure, it may have difficulty to provide proper performance.
- \* If you pass the limit of pneumatic pressure for the unit, it causes the failure of the operation. Please, lower your air pressure of the air supply than the expected level.

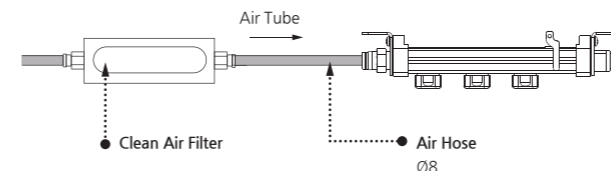

\* Please use the proper air filter for your working environment. [We suggest you to use a clean air filter (Filteration:0.01µm) for clean environment.]

**Types of Air Use**

Please supply air into an ion bar either one of CDA(Clean Dry Air) or N2 if possible. In the clean environment, we suggest you to use a clean air filter(Filteration:0.01µm) in order to pass impurities in the compressed air through the filter when using the ion bar.

**Allowed Air Pressure**

Allowable air pressure determination is strongly required when installing since the air pressure is relevant to ionizer performance. The maximum allowable working pressure is 0.5 MPa. Please, lower your air pressure of the air supply than the expected level.

**Recommended Model (For Clean Nipple)**

Material	Shape	Screw Size
Polypropylene (PP)	Straight or Elbow	Taper Screw 01(R1/8)

**How to connect**

Refer to the figure below to connect the product.

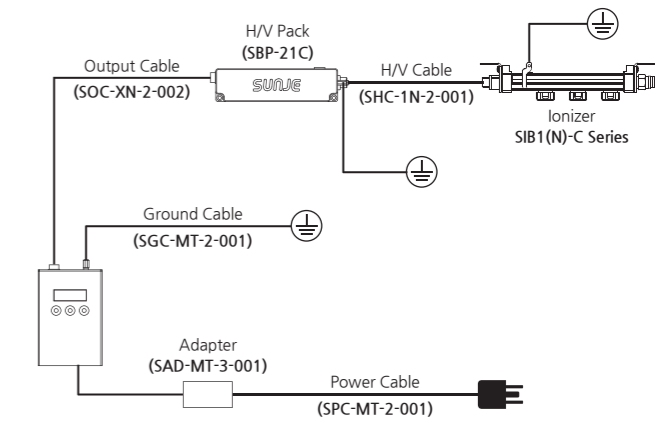

**How to connect the Interface**

For the specification of the Interface to be used, refer to the table below.

Interface	Output	INTERFACE						RMS	
		6	5	4	3	2	1	2	1
Interface	Output	1	High Voltage Abnormal Alarm	Alarm	Normal				
		2	Tip Cleaning Alarm	Alarm	Normal				
		3	Signal Ground	-					
		4	Run / Stop State	Run	Stop				
Interface	Input	5	Remote Input	Stop	Run				
		6	Remote Com	-					
RMS		1	RS485+	-					
		2	RS485-	-					

**5 How to set**

**WARNING**

\* Do not tamper with the set value. The malfunction might arise.

**Setting order**

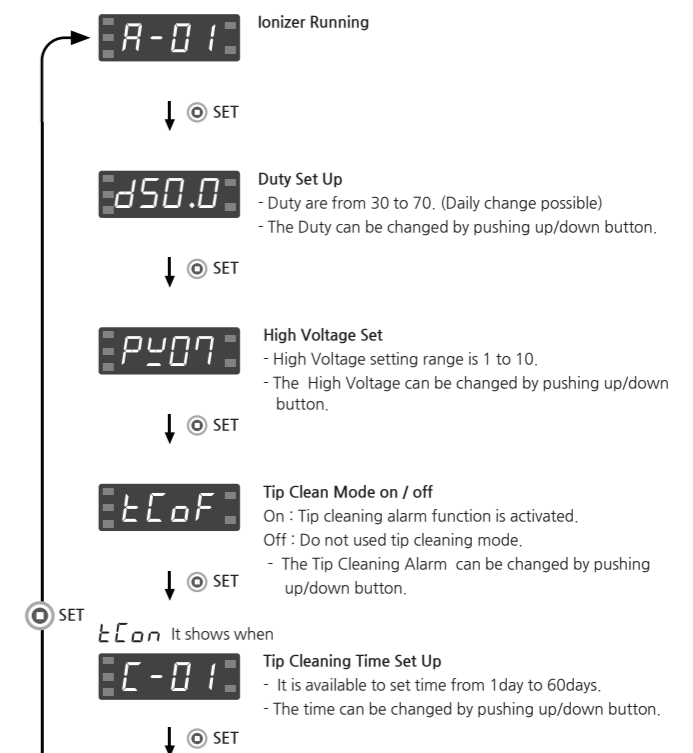

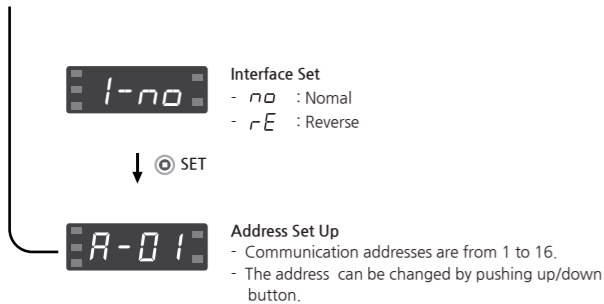

**6 Maintenance**

Maintenance is an essential item for maintaining its capacity. Please conduct a routine maintenance according to the below description. The life time of a discharge needle can be a difference depending on using circumstance.

**CAUTION**

- \* This device uses the high level of voltage. When operating maintenance, please power off and unplug the device. Otherwise, there might be in case of electric shock or fire damage.
- \* The discharge needle is very sharp at the edge. Do not physically (directly) touch the discharge needle.
- \* When cleaning the discharge needle using an organic solvent, do not use the organic solvent to clean the socket around the discharge needle.

**Discharge needle cleaning**

The contamination level of discharge needle is different among the areas where the user installs, please maintain own cleaning period that suits your environment.

**Discharge needle cleaning order**

- Be sure to power off before cleaning the ionizer.
- Please clean it as the table below.

**※ Cleaning with a cotton swab**  
 After moistening a cotton swab with alcohol, wipe the discharge needle from side to side with the swab. (do not use acetone)

- Replace the damaged discharge needle.
- After the cleaning, let the alcohol applied to the discharge needle surface evaporate completely and then operate the Ion Bar.
- Please record the cleaning process as a reference in the file.

**Discharge needle maintenance**

If the discharge needle broken or severely damaged, please replace the needle socket immediately. The needle socket becomes less durable with product usage time. To maintain the performance of the product, we recommend replacing the needle socket every one year.

**7 Problem solving**

**Checklist before called**

Problem	Identifying Problem	Solution
The product does not work.	Is your power cable still plugged in?	Please re-plug the power cable and then turn the device on again.
	Was the proper voltage level applied for this set-up?	Please use the proper level of power input for the device. (AC 100~240V, 50/60Hz)
There is no ionization.	Is there any conductive material around the device?	Please refer to "Installation & Connection," for setting the proper target distance from the device.
	Does the installed environment have too high/low level of humidity or temperature?	Please install the device upon the proper working specification.
The ionizing performance has been decreased.	Can't possibly ground the device?	Please refer to "Installation & Connection," for (proper) grounding the device.
	Any damages or cut on the cables?	You need to replace the cables if it gets cut or damaged.
	Any contamination on the discharge needle?	Please refer to "Maintenance," for cleaning the discharge needle.

**8 Dimensions**

**SIB1(N)-C Series (Ionizer)**

Model No.	Tip Q'ty	A	B	C	D	Middle Bkt Q'ty
SIB1(N)-07A-C	1	88	-	112	134	-
SIB1(N)-16A-C	3	168	80	192	214	-
SIB1(N)-20A-C	4	208	120	232	254	-
SIB1(N)-32A-C	7	328	240	352	374	-
SIB1(N)-48A-C	11	488	400	512	534	-
SIB1(N)-64A-C	15	648	560	672	694	-
SIB1(N)-80A-C	19	808	720	832	854	-
SIB1(N)-96A-C	23	968	880	992	1014	-

**SBP-21C (H/V Pack)**

**SNC-21 (Controller)**

※ Bracket is an option.

**9 Specification**

**SIB1(N)-C Series (Ionizer)**

Parameter	Description / Value
Ion-Generation Method	Corona Discharge Pulse AC
Air Purge Supply Pressure	≤0.5MPa (CDA, N2)
Air Purge Connection Port	Pipe Thread 1/8"
Ion Balance	within ±35V (300mm)
Operating Distance	50mm ~ 1,000mm
Operation Circumstance	0°C ~ +50°C (32°F ~ 122°F), 35% ~ 85% RH
Ozone(O3) Concentration	≤0.05ppm
Main Body Material	Non-Flammable ABS (Level V0), Stainless Steel
Electrode Material	Standard : Tungsten Option : Silicon
Electrode Replacement	Cartridge type
Mounting Method	Bolt Mounting with Bracket
High Voltage Cable	Insulation Cable 2m (UL3239_20kV - 1007AWG18)
Warranty	1 year

※ The appearance and specification of the product may be changed without prior notice for the improvement of the product.

**CAUTION** \* Handle with care. Warranty doesn't cover mishandling damage.

**SNC-21 (Controller)**

Parameter	Description / Value
Input Power	DC 24V (±5%)
Power Consumption	Max. 4.8W
Connector	Power (DC24V) : DC JACK RS-485 & Interface : Terminal Block 3.81mm Pitch
Operation Circumstance	0°C ~ +50°C (32°F ~ 122°F), 35% ~ 85% RH
Function	Alarm High Voltage Alarm, Tip Cleaning Timer Warning
	Interface - Run/Stop State : Run-Closed / Stop-Open - High Voltage Alarm : Normal-Open / Alarm-Closed - Tip Cleaning Timer Warning : Normal-Open / Alarm-Closed - Remote Input
	RMS Real Monitoring System (RS485)
Warranty	1 year

※ The appearance and specification of the product may be changed without prior notice for the improvement of the product.

**SUNJE Hi-Tek Co., Ltd.**

www.sunstat.com

**Head Office & Factory (Busan)**  
 8 Cheonggwang-gil, Ilgwang-eup,  
 Gijang-Gun, Busan, Korea  
 T) +82-51-720-7500 F) +82-51-720-7501

**Sunje Japan Co., Ltd.**  
 Dai 7 Matsuya Bldg 10F 1005 2-23,  
 Honmachibashi, Chuo-ku, Osaka, Japan  
 T) +81-6-6949-5001 F) +81-6-6949-5011

**Sales Headquarter (Osan)**  
 3rd floor, 129-20, Gyeonggi-daero 632  
 beon-gil, Osan-si, Gyeonggi-do, Korea  
 T) +82-31-203-9034 F) +82-31-202-9034

**Sunje (SHANGHAI) Trading Co., Ltd.**  
 Block C, 4F, No.482, Hongxu Road, Minhang  
 District, Shanghai, China  
 T) +86-21-5433-9761 F) +86-21-5433-9762

**Customer Center** +82-70-7714-9033  
**Sales Contact** +82-31-203-9034

**Sunje Technology Co., Ltd.**  
 2F, No.6, Lane.102, Sinhe Rd, Sinfong Township,  
 Hsinchu County, Taiwan 30472  
 T) +886-3-568-7891 F) +886-3-568-7950